



System 25

Work cabinets

[Type 1](#) Sys 25 2

[Type 2](#) Sys 25 3

[Type 3](#) Sys 25 4

Accessories

[Cabinet flanges](#) Sys 25 5



System 25

All components RoHS-compatible according to directive 2002/95/EC (RoHS).

Design:

- Work cabinet for placing on a table/plane surface
- Dimensions of the base: 1000 x 6000 mm
- Height of side panels: 200, 500 or 750mm (total heights: 410, 710, 960 mm)
- Vacuum moulded top made of transparent PETG with a pane of tempered glass
- Pane corners made of PP in the colours white (-5) or red (-4)
- Sides made of transparent PETG
- Corners made of anodized aluminium
- Bottom edge provided with a non-skid rubber edge
- Recommended airflow: 220, 550 or 850 m³/h dependent on the height of the side panels
- Optional flange for extraction available
- NB! NB! Can be delivered with doors



Working area

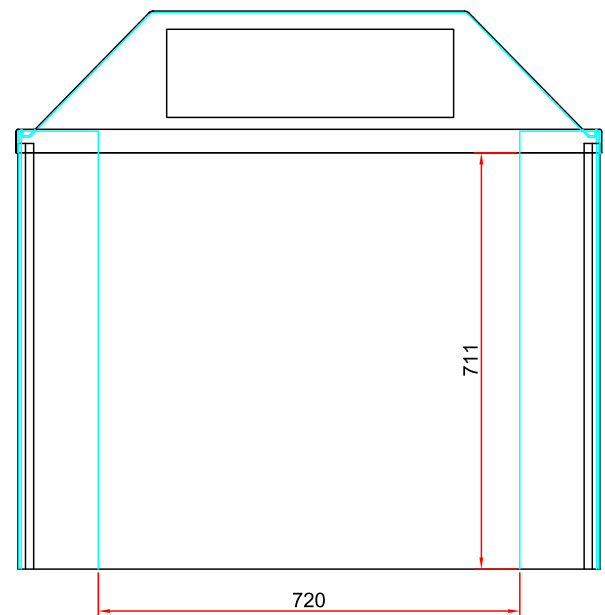
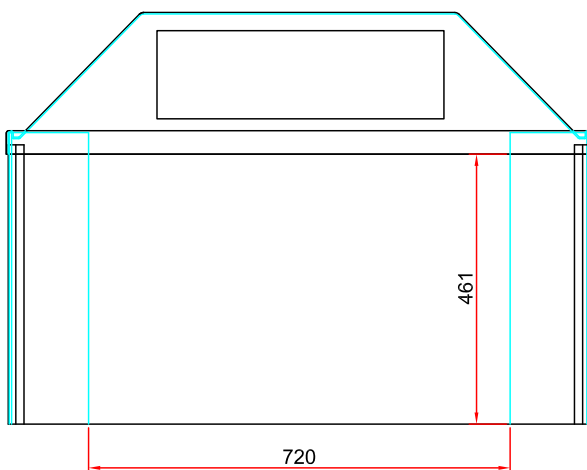
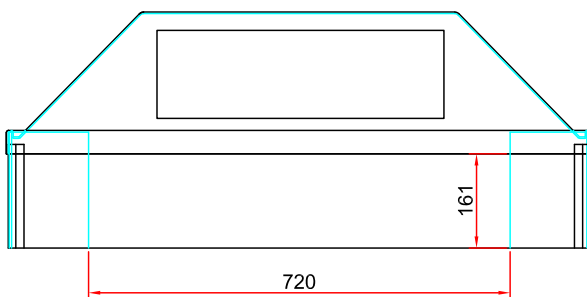



System 25

All components RoHS-compatible according to directive 2002/95/EC (RoHS).

Design:

- Work cabinet for placing on a table/plane surface
- Dimensions of the base: 635 x 480 mm
- Total height: 350 mm
- Made of vacuum moulded PETG in the colours transparent (-0) or opal ((-0-7)
- Provided with a pane made of safety glass
- Pane corners made of PP in the colours white (-5) or red (-4)
- Recommended airflow: 117 m³/h
- Optional flange for extraction available

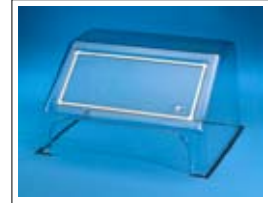

Working area

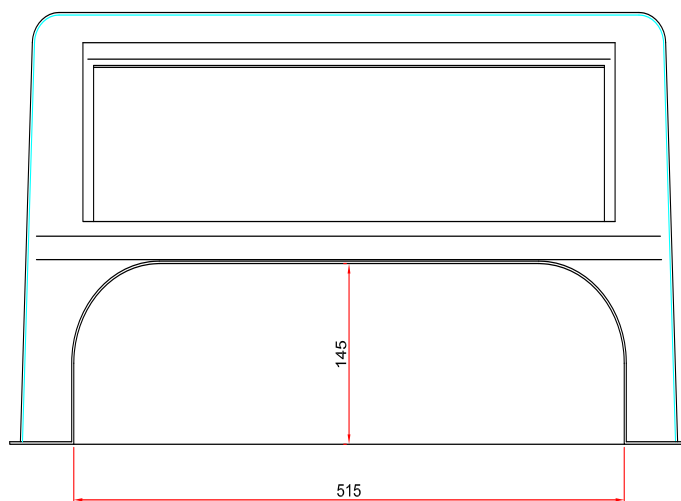



System 25

All components RoHS-compatible according to directive 2002/95/EC (RoHS).

Design:

- Work cabinet for placing on a table/plane surface
- Dimensions of the base: 420 x 320 mm
- Height of side panels: 400 total height: 515 mm)
- Vacuum moulded top made of transparent PETG inclusive of 2 stub pipes
- Sides made of steel with a white polyester powder-coating on the surface
- Flanges and joint with damper in the colours white (-5) or red (-4)
- Flanges, stub pipes and joint with damper $\varnothing 75$ mm
- Recommended airflow: 204 m³/h



Working area

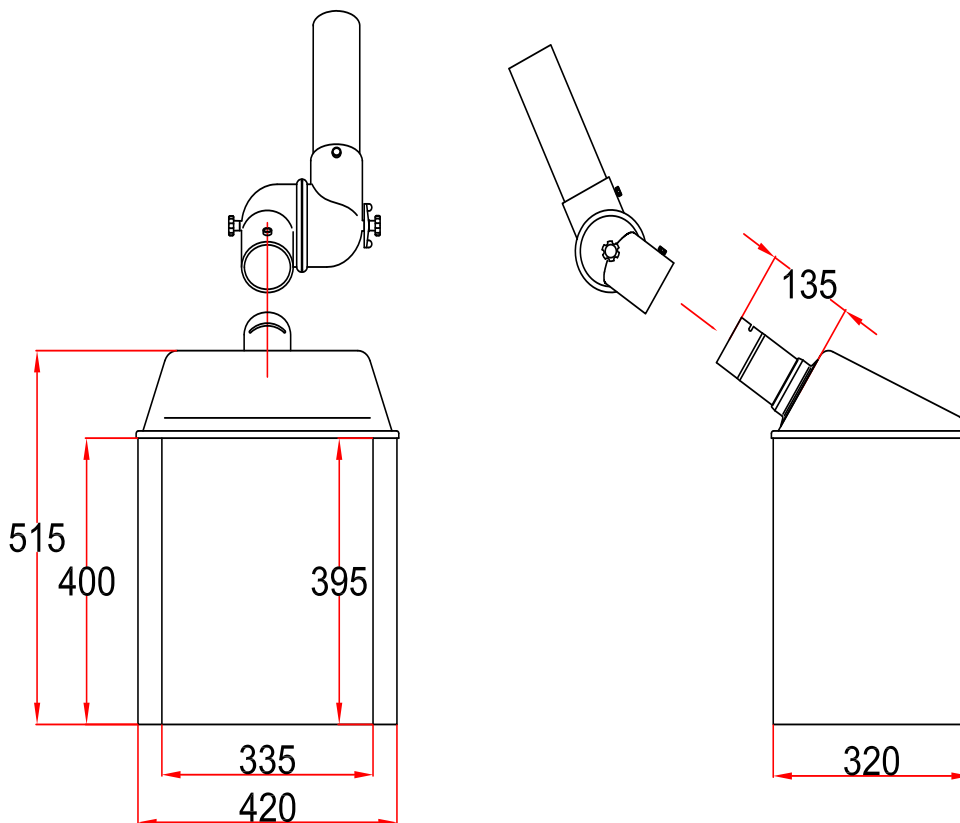



System 25

- Cabinet flanges to connect ventilating duct and work cabinet
- Diameter (muff coupling size), see drawing below
- Made of polypropylene (PP): white (-5) or red (-4)
- Mounting and position optional



Model # 4-50-13

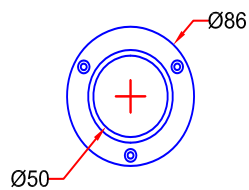

Model # 4-100-13

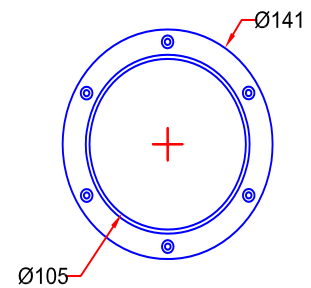

Model # 4-75-13

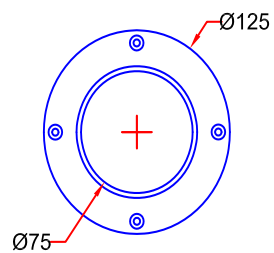

Model # 4-125-13

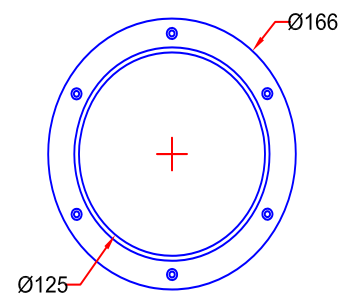

Model # 4-80-13

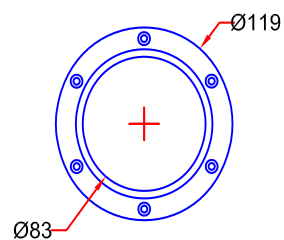

Model # 4-160-13

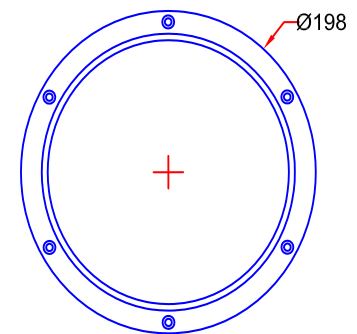

Model # 4-100-13

