



System 50 - Antistatic (AS)

- Metal hood recommended when extracting gases, fumes and light dust concentrations
- Diameter of hood: Ø200 mm
- Hood and connection tube made of chromated TCP Aluminium for permanent conductivity
- Flange of conductive polypropylene (PP)



Capture efficiency

The relative velocity of the gas flow is not optimal for the hood position and the hood is not recommended for use in the hood position. The hood is not recommended for use in the hood position. The hood is not recommended for use in the hood position.

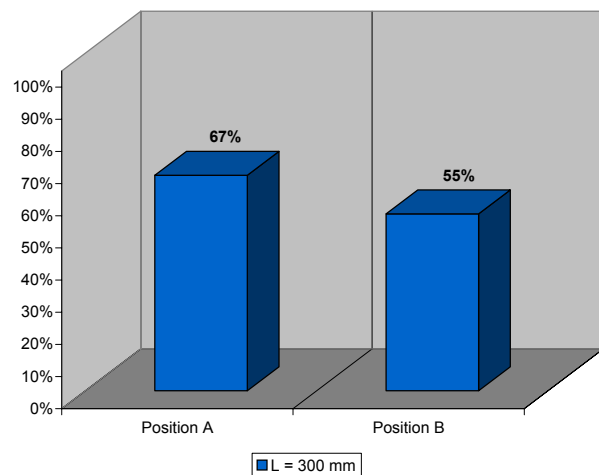
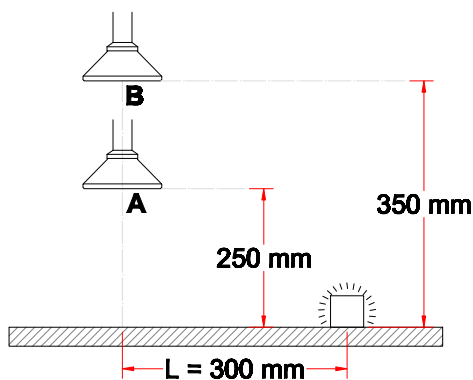

Drawing

