



System 50 - Aluminium (AL)

- Round hood recommended for light fumes, gases and over small open vessels
- Diameter of hood: $\varnothing 385$ mm
- Increased stability when moving the hood due to reinforced rim of the hood
- Increased efficiency at an angled position
- Hood made of transparent PETG, resistant to solvents
- Connection tube made of anodized aluminium - surface 10μ
- The transparent hood assists in keeping a good view of the work place
- Colours of flange available: white (-5) and red (-4)



Capture efficiency

The relatively low efficiency indicates, that the illustrated position is not optimal for this hood. For system 100 other measurements have been made for a similar round hood - see article no. [1-10050](#).

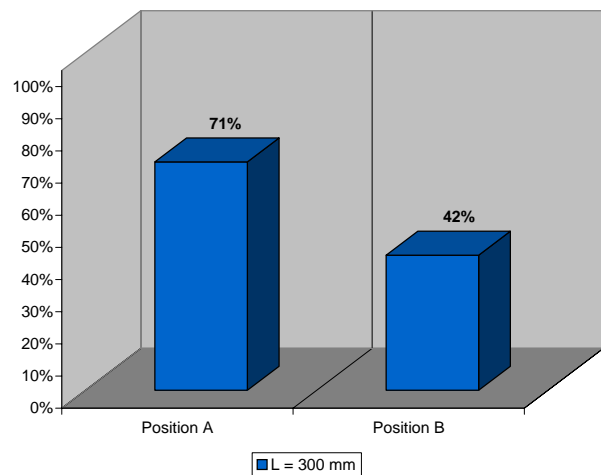
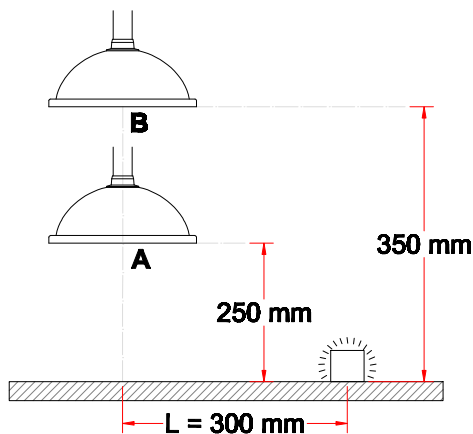

Drawing

